

LNK632DG

LinkSwitch-II Family



Energy-Efficient, Accurate CV Switcher With CC Control for Adapters and Chargers

Product Highlights

Dramatically Simplifies CV Converters

- Eliminates optocoupler and all secondary CV/CC control circuitry
- Eliminates all control loop compensation circuitry
- Enables Clampless™ designs

Advanced Performance Features

- Compensates for cable voltage drop
- Compensates for external component temperature variations
- Very tight IC parameter tolerances using proprietary trimming technology
- Frequency jittering greatly reduces EMI filter cost

Advanced Protection/Safety Features

- Auto-restart protection reduces power delivered by about 85% for output short circuit and control loop faults (open and shorted components)
- Hysteretic thermal shutdown – automatic recovery reduces power supply returns from the field

EcoSmart® – Energy Efficient

- Easily meets all global energy efficiency regulations with no added components
- No-load consumption down to <30 mW at 230 VAC input with bias winding
- ON/OFF control provides constant efficiency down to very light loads – ideal for EISA and ENERGY STAR regulations
- No current sense resistors – maximizes efficiency

Green Package

- Halogen free and RoHS compliant package

Applications

- Chargers for cell/cordless phones, PDAs, MP3/portable audio devices, adapters, etc.

Description

The LNK632DG dramatically simplifies low power CV/CC charger designs by eliminating an optocoupler and secondary control circuitry. The device uses an ON/OFF control technique to provide very tight output voltage regulation, in addition to output current control ideal for battery charging applications. The combination of proprietary IC trimming and E-Shield™ transformer construction techniques enables Clampless designs with the LNK632DG when an external bias circuit is used.

The device incorporates a 700 V power MOSFET, a novel ON/OFF control state machine, a high voltage switched current source for self biasing, frequency jittering, cycle-by-cycle current limit and hysteretic thermal shutdown circuitry onto a monolithic IC.

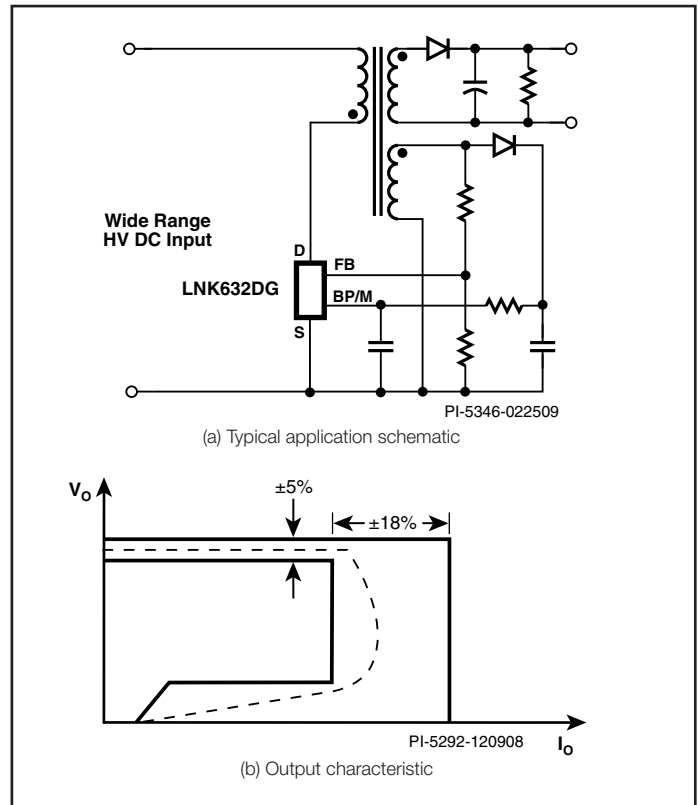

Figure 1. Typical Application – Not a Simplified Circuit (a) and Output Characteristic Envelope (b).

Output Power Table

Product ³	85-265 VAC	
	Adapter ¹	Open Frame ²
LNK632DG	3.1 W	3.1 W

Table 1. Output Power Table.

Notes:

1. Minimum continuous power in a typical non-ventilated enclosed adapter measured at +50 °C ambient.
2. Maximum practical continuous power in an open frame design with adequate heatsinking, measured at 50 °C ambient.
3. Packages: D: SO-8C.

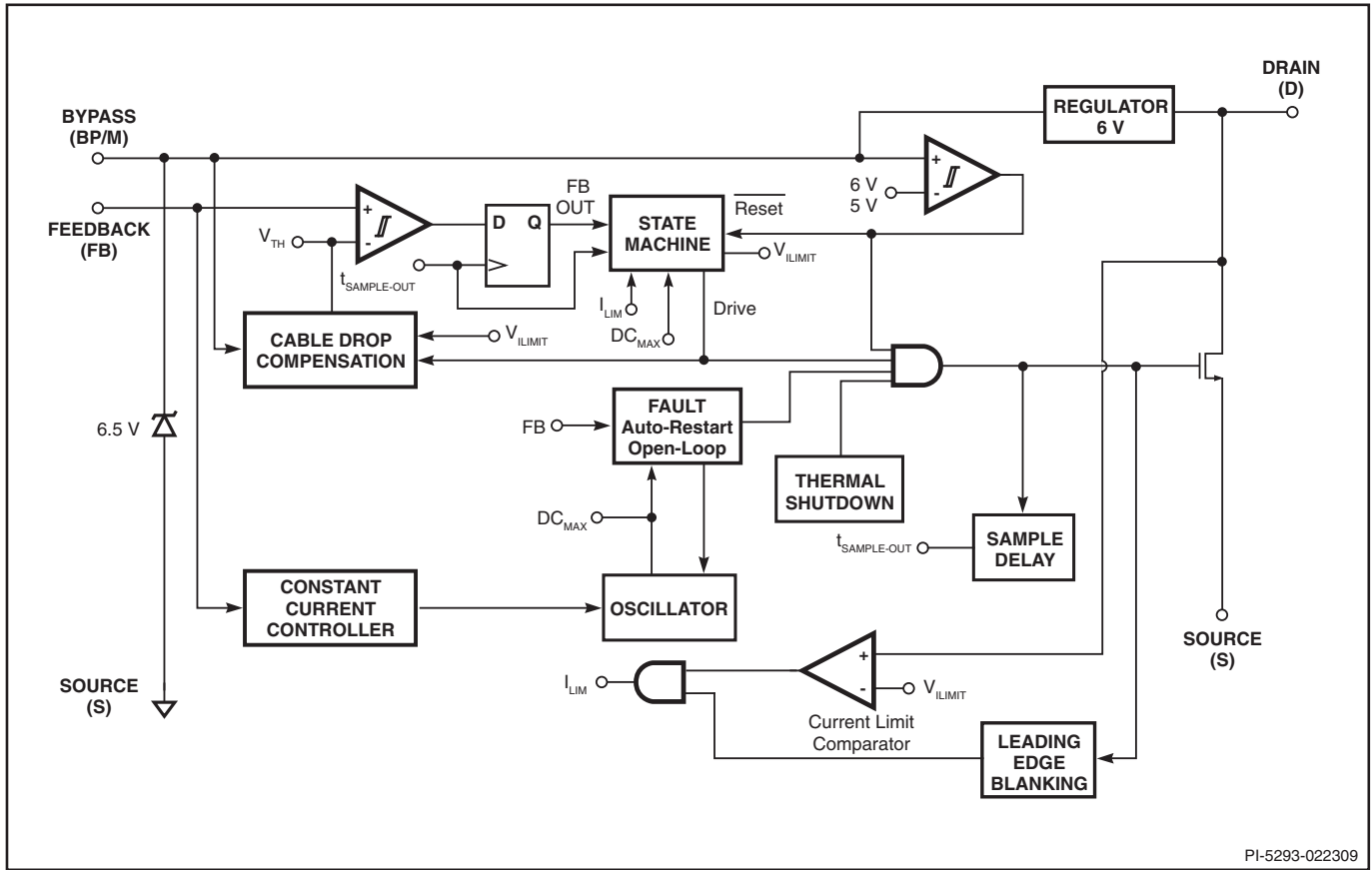

PI-5293-022309

Figure 2 Functional Block Diagram.

Pin Functional Description

DRAIN (D) Pin:

This pin is the power MOSFET drain connection. It provides internal operating current for both start-up and steady-state operation.

BYPASS/MULTI-FUNCTIONAL Programmable (BP/M) Pin:

This pin has multiple functions:

1. It is the connection point for an external bypass capacitor for the internally generated 6 V supply.
2. It is a mode selection for the cable drop compensation.

FEEDBACK (FB) Pin:

During normal operation, switching of the power MOSFET is controlled by this pin. This pin senses the AC voltage on the bias winding. This control input regulates both the output voltage in CV mode and output current in CC mode based on the Flyback voltage of the bias winding. The internal inductance correction circuit uses the forward voltage on the bias winding to sense the bulk capacitor voltage.

SOURCE (S) Pin:

This pin is internally connected to the output MOSFET source for high voltage power and control circuit common returns.

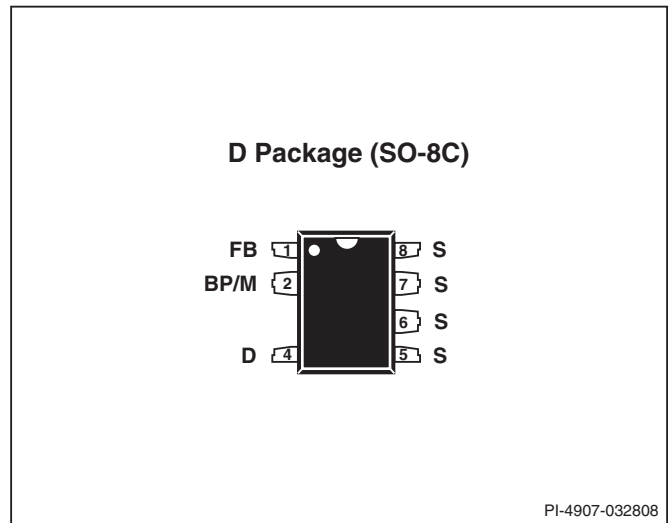

PI-4907-032808

Figure 3. Pin Configuration.

LNK632DG Functional Description

The LNK632DG combines a high voltage power MOSFET switch with a power supply controller in one device. Similar to the LinkSwitch-LP and TinySwitch-III it uses a simple ON/OFF control to regulate the output voltage. In addition, the switching frequency is modulated to regulate the output current to provide a constant current characteristic. The LNK632DG controller consists of an oscillator, feedback (sense and logic) circuit, 6 V regulator, over-temperature protection, frequency jittering, current limit circuit, leading-edge blanking, frequency control for constant current regulation and ON/OFF state machine for CV control.

Constant Current Control (CC) Operation

As the output voltage and therefore the Flyback voltage across the bias winding ramps up, the feedback pin voltage increases. The switching frequency is adjusted as the feedback pin voltage increases to provide a constant output current regulation.

Constant Voltage (CV) Operation

As the feedback pin approaches V_{FBth} from the constant current regulation mode, the power supply transitions into CV operation. The switching frequency at this point is at its maximum value, corresponding to the peak power point of the CCCV characteristic. The controller regulates the feedback pin voltage to remain at V_{FBth} using an ON/OFF state-machine. The feedback pin voltage is sampled 2.5 μ s after the turn-off of the high voltage switch. At light loads the current limit is also reduced to decrease the transformer flux density.

Output Cable Compensation

This compensation provides a constant output voltage at the end of the cable over the entire load range in CV mode. As the converter load increases from no-load to the peak power point (transition point between CV and CC) the voltage drop introduced across the output cable is compensated by increasing the feedback pin reference voltage. The controller determines the output load and therefore the correct degree of compensation based on the output of the state machine. Cable drop compensation for a 26 AWG (0.4 Ω) cable is selected with $C_{BP} = 1 \mu$ F and for a 28 AWG (0.75 Ω) cable with $C_{BP} = 10 \mu$ F.

Auto-Restart and Open-Loop Protection

In the event of a fault condition such as an output short or an open loop condition the LNK632DG enters into an appropriate protection mode as described below.

In the event the feedback pin voltage during the Flyback period falls below 0.7 V before the feedback pin sampling delay (~2.5 μ s) for a duration in excess of ~300 ms (auto-restart on-

time (t_{AR-ON}) the converter enters into Auto-restart, wherein the power MOSFET is disabled for 1.2 seconds (~20% Auto-Restart duty cycle). The auto-restart alternately enables and disables the switching of the power MOSFET until the fault condition is removed.

In addition to the conditions for auto-restart described above, if the sensed feedback pin current during the Forward period of the conduction cycle (switch "on" time) falls below 120 μ A, the converter annunciates this as an open-loop condition (top resistor in potential divider is open or missing) and reduces the Auto-restart time from 300 ms to approximately 6 clock cycles (60 μ s), whilst keeping the disable period of 1.2 seconds. This effectively reduces the Auto-Restart duty cycle to less than 0.05%.

Over-Temperature Protection

The thermal shutdown circuitry senses the die temperature. The threshold is set at 142 $^{\circ}$ C typical with a 60 $^{\circ}$ C hysteresis. When the die temperature rises above this threshold (142 $^{\circ}$ C) the power MOSFET is disabled and remains disabled until the die temperature falls by 60 $^{\circ}$ C, at which point the MOSFET is re-enabled.

Current Limit

The current limit circuit senses the current in the power MOSFET. When this current exceeds the internal threshold (I_{LIMIT}), the power MOSFET is turned off for the remainder of that cycle. The leading edge blanking circuit inhibits the current limit comparator for a short time (t_{LEB}) after the power MOSFET is turned on. This leading edge blanking time has been set so that current spikes caused by capacitance and rectifier reverse recovery time will not cause premature termination of the MOSFET conduction.

6 V Regulator

The 6 V regulator charges the bypass capacitor connected to the BYPASS pin to 6 V by drawing a current from the voltage on the DRAIN, whenever the MOSFET is off. The BYPASS pin is the internal supply voltage node. When the MOSFET is on, the device runs off of the energy stored in the bypass capacitor. Extremely low power consumption of the internal circuitry allows the LNK632DG to operate continuously from the current drawn from the DRAIN pin. A bypass capacitor value of either 1 μ F or 10 μ F is sufficient for both high frequency decoupling and energy storage.

Clampless Design Considerations

Ensure that worst-case high line, peak drain voltage is below the BV_{DSS} specification of the internal MOSFET and ideally <650 V to allow margin for design variation.

Absolute Maximum Ratings^(1,5)

DRAIN Voltage	-0.3 V to 700 V
DRAIN Peak Current	232 (350) mA ⁽⁴⁾
Peak Negative Pulsed Drain Current	-100 mA ⁽²⁾
Feedback Voltage	-0.3 V to 9 V
Feedback Current	100 mA
BYPASS Pin Voltage	-0.3 V to 9 V
Storage Temperature	-65 °C to 150 °C
Operating Junction Temperature	-40 °C to 150 °C
Lead Temperature ⁽⁴⁾	260 °C

Notes:

- All voltages referenced to SOURCE, $T_A = 25\text{ °C}$.
- Duration not to exceed 2 ms.
- 1/16 in. from case for 5 seconds.
- The higher peak DRAIN current is allowed while the DRAIN voltage is simultaneously less than 400 V.
- Maximum ratings specified may be applied, one at a time without causing permanent damage to the product. Exposure to Absolute Maximum ratings for extended periods of time may affect product reliability.

Thermal Impedance

Thermal Impedance: D Package:

(θ_{JA})	100 °C/W ⁽²⁾ ; 60 °C/W ⁽³⁾
(θ_{JC}) ⁽¹⁾	30 °C/W

Notes:

- Measured on pin 8 (SOURCE) close to plastic interface.
- Soldered to 0.36 sq. in. (232 mm²), 2 oz. (610 g/m²) copper clad.
- Soldered to 1 sq. in. (645 mm²), 2 oz. (610 g/m²) copper clad.

Parameter	Symbol	Conditions		Min	Typ	Max	Units
		SOURCE = 0 V; $T_J = -40$ to 125 °C (Unless Otherwise Specified)					
Control Functions							
Output Frequency	f_{OSC}	$T_J = 25\text{ °C}$	$V_{FB} = V_{FBth}$	98	105	112	kHz
Frequency Ratio (Constant Current)	$f_{RATIO(CC)}$	$T_J = 25\text{ °C}$ Between $V_{FB} = 1.0\text{ V}$ and $V_{FB} = 1.6\text{ V}$		1.57	1.635	1.7	
Frequency Jitter		Peak-Peak Jitter Compared to Average Frequency, $T_J = 25\text{ °C}$			± 7		%
Ratio of Output Frequency at Auto-RST	$f_{OSC(AR)}$	$T_J = 25\text{ °C}$ Relative to f_{OSC}		12	16.5	21	%
Maximum Duty Cycle	DC_{MAX}	(Note 2,3)			55		%
Feedback Pin Voltage	V_{FBth}	$T_J = 25\text{ °C}$ See Figure 10, $C_{BP} = 10\text{ }\mu\text{F}$		2.015	2.040	2.065	V
Feedback Pin Voltage Temperature Coefficient	TC_{VFB}				-0.01		%/°C
Feedback Pin Voltage at Turn-Off Threshold	$V_{FB(AR)}$			0.65	0.72	0.79	V
Cable Compensation Factor	v_{FB}	See Figure 10	$C_{BP} = 1\text{ }\mu\text{F}$		1.06		
			$C_{BP} = 10\text{ }\mu\text{F}$		1.09		

Parameter	Symbol	Conditions SOURCE = 0 V; T _J = -40 to 125 °C (Unless Otherwise Specified)	Min	Typ	Max	Units
Control Functions (cont.)						
Minimum Switch ON-Time	t _{ON(min)}	T _J = 25 °C See Note 3		700		ns
Feedback Pin Sampling Delay	t _{FB}	T _J = 25 °C See Figure 10	2.35	2.55	2.75	μs
DRAIN Supply Current	I _{S1}	FB Voltage > V _{FBth}		260	330	μA
	I _{S2}	FB Voltage = V _{FBTH} - 0.2, Switch ON-Time = t _{ON} (MOSFET Switching at f _{OSC})		440	520	
BYPASS Pin Charge Current	I _{CH1}	V _{BP} = 0 V	-5	-3.4	-1.8	mA
	I _{CH2}	V _{BP} = 4 V	-4	-2.3	-1	
BYPASS Pin Voltage	V _{BP}		5.65	6.00	6.25	V
BYPASS Pin Voltage Hysteresis	V _{BPH}		0.7	1.0	1.2	V
BYPASS Pin Shunt Voltage	V _{SHUNT}	I _{BP} = 10 mA	6.2	6.5	6.8	V
Circuit Protection						
Current Limit	I _{LIMIT}	di/dt = 36 mA/μs T _J = 25 °C	135	145	155	mA
Power Coefficient	I ² f	I ² f = I _{LIMIT(TYP)} ² × f _{OSC(TYP)} T _J = 25 °C	0.9 x I ² f		1.17 x I ² f	A ² Hz
Leading Edge Blanking Time	t _{LEB}	T _J = 25 °C See Note 3	170	215		ns
Thermal Shutdown Temperature	T _{SD}		135	142	150	°C
Thermal Shutdown Hysteresis	T _{SDH}			60		°C

Parameter	Symbol	Conditions		Min	Typ	Max	Units
		SOURCE = 0 V; $T_J = -40$ to 125 °C (Unless Otherwise Specified)					
Output							
ON-State Resistance	$R_{DS(ON)}$	$I_D = 13$ mA	$T_J = 25$ °C		45	53	Ω
			$T_J = 100$ °C		68	79	
OFF-State Leakage	I_{DSS1}	$V_{DS} = 560$ V See Figure 11 $T_J = 125$ °C See Note 1				50	μ A
	I_{DSS2}	$V_{DS} = 375$ V See Figure 11 $T_J = 50$ °C			15		
Breakdown Voltage	BV_{DSS}	$T_J = 25$ °C See Figure 11		700			V
DRAIN Supply Voltage				50			V
Auto-Restart ON-Time	t_{AR-ON}	$V_{FB} = 0$ See Note 3			300		ms
Auto-Restart OFF-Time	t_{AR-OFF}	See Note 3			1.2	2.0	s
Open-Loop FB Pin Current Threshold	I_{OL}	See Note 3			-120		μ A
Open-Loop ON-Time		See Note 3			60		μ s

NOTES:

- I_{DSS1} is the worst case OFF state leakage specification at 80% of BV_{DSS} and maximum operating junction temperature. I_{DSS2} is a typical specification under worst case application conditions (rectified 265 VAC) for no-load consumption calculations.
- When the duty-cycle exceeds DC_{MAX} the LNK632DG operates in on-time extension mode.
- This parameter is derived from characterization.

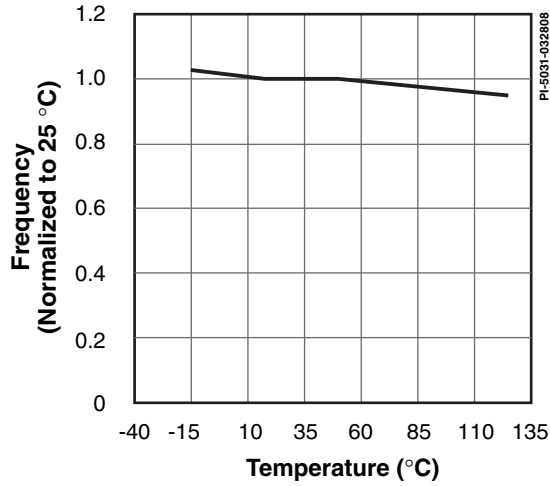

Figure 4. Output Frequency vs. Temperature.

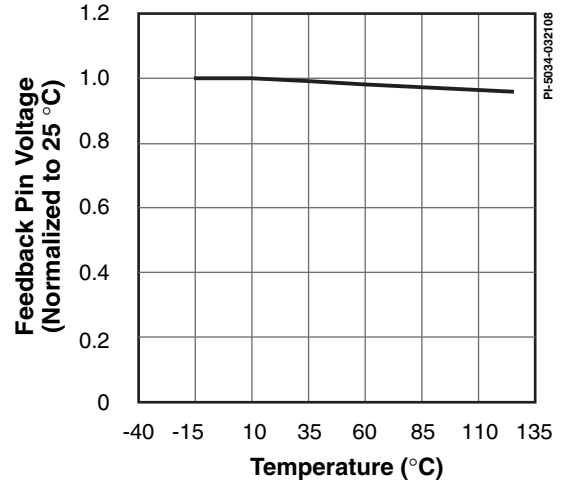

Figure 5. Feedback Pin Voltage vs. Temperature

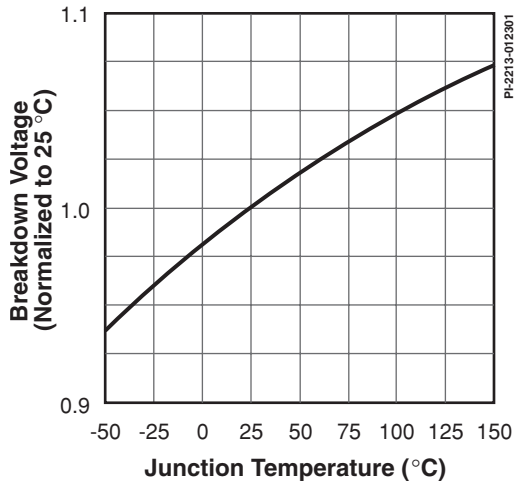

Figure 6. Breakdown vs. Temperature.

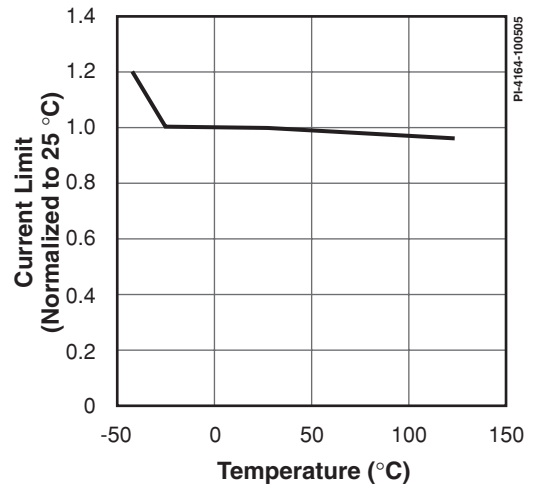

Figure 7. Current Limit vs. Temperature.

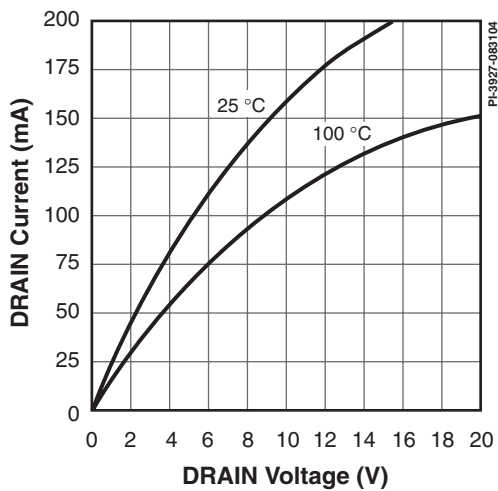

Figure 8. Output Characteristics.

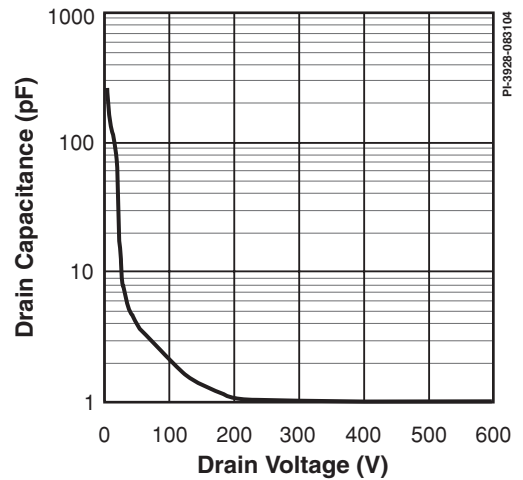

Figure 9. C_{OSS} vs. Drain Voltage.

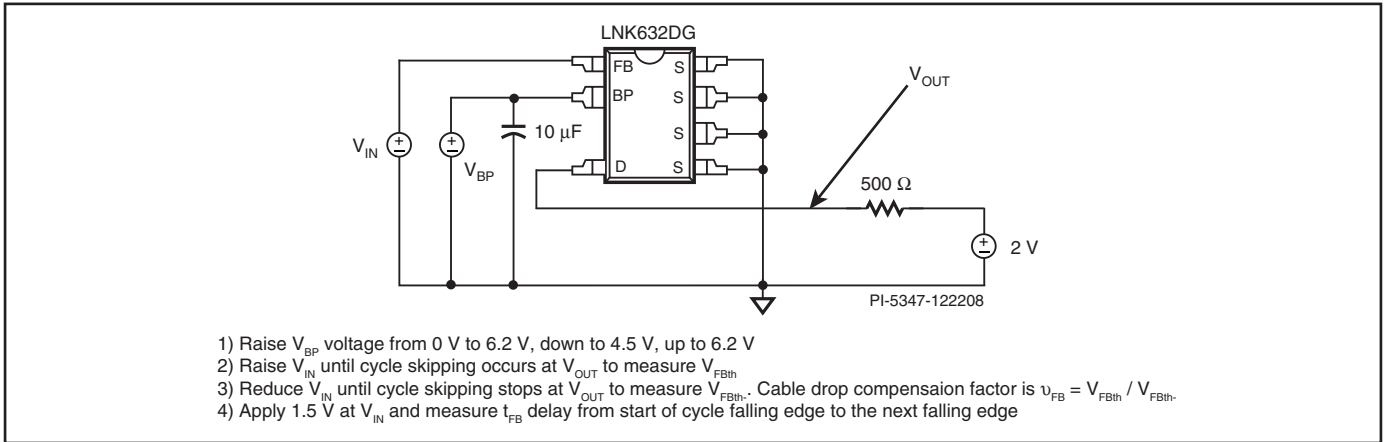

Figure 10. Test Set-up for Feedback Pin Measurements.

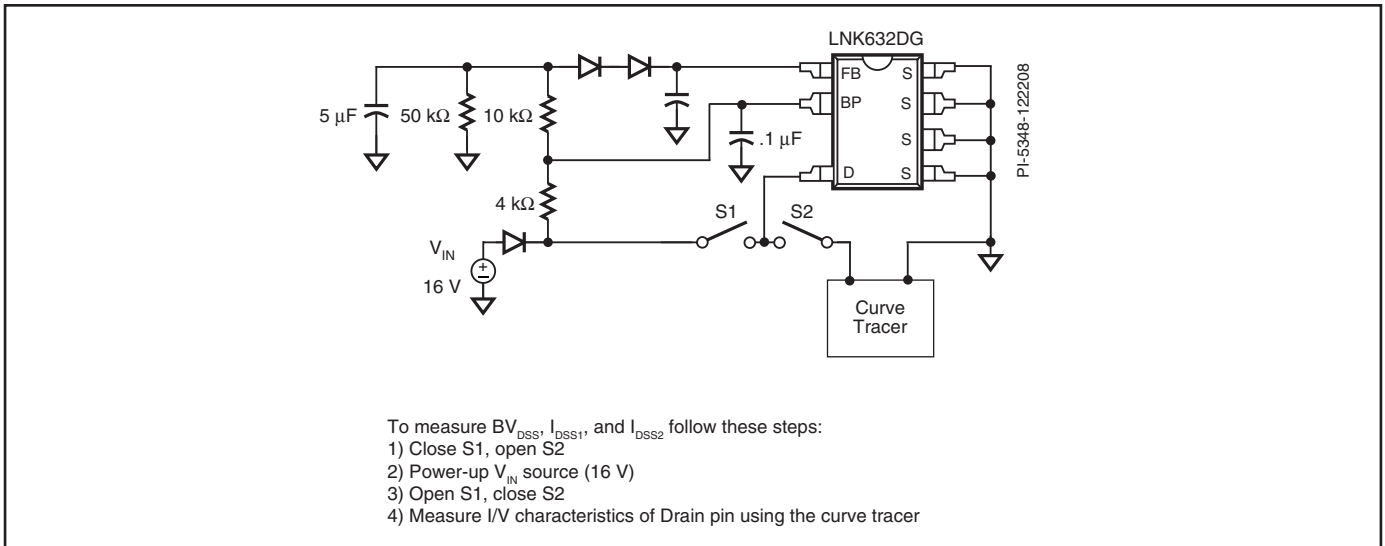
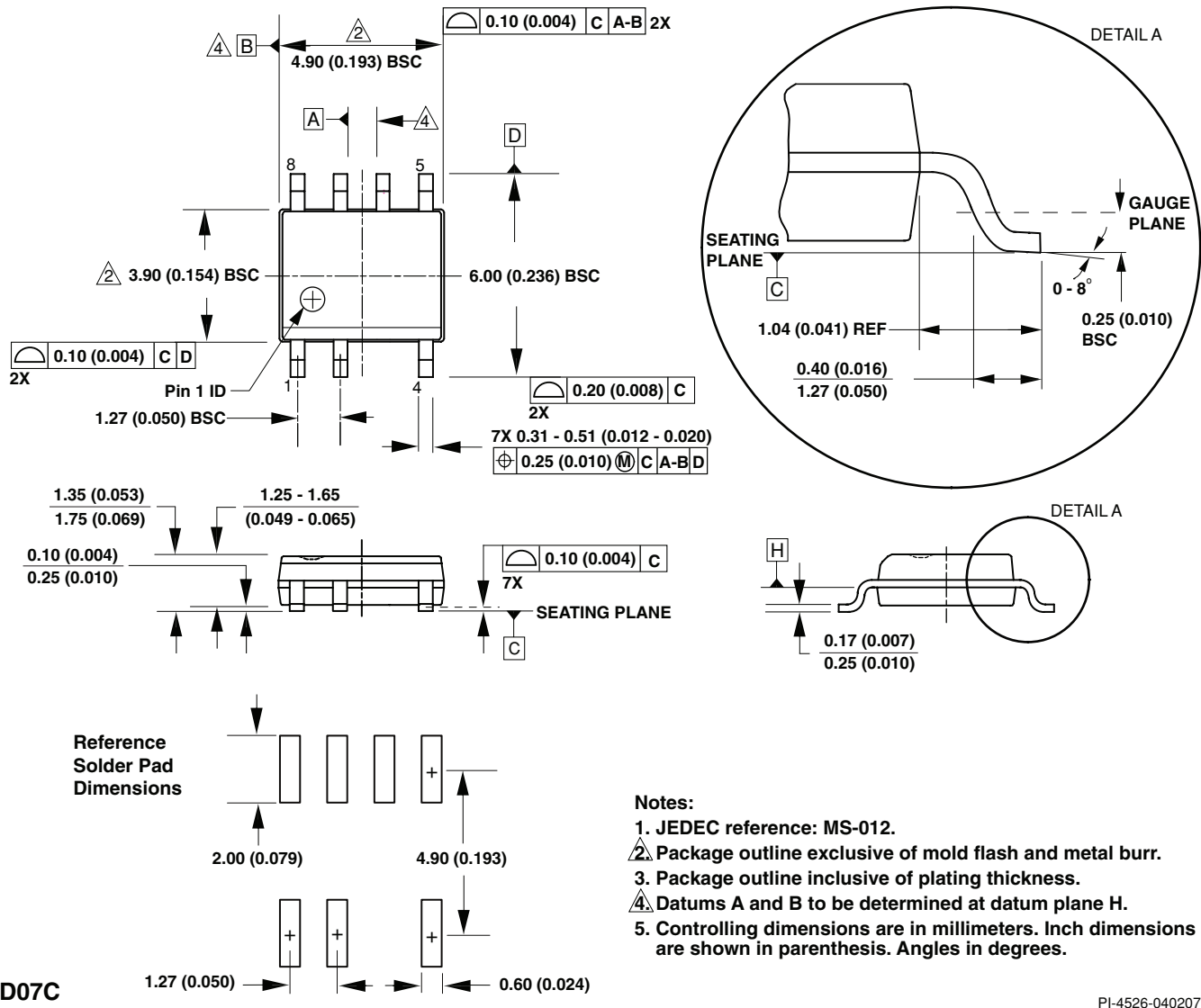
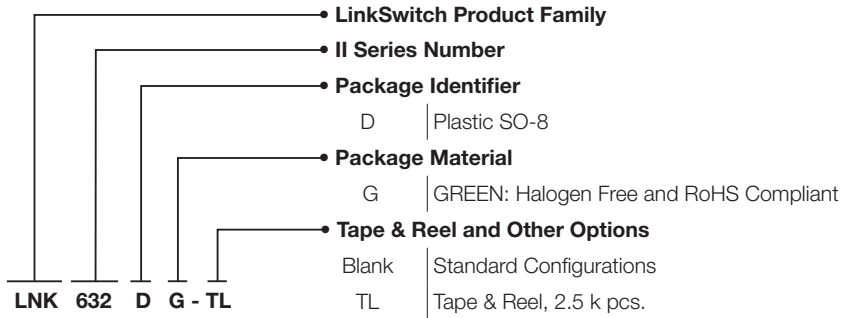

Figure 11. Test Set-up for Leakage and Breakdown Tests.

SO-8C



Part Ordering Information



Revision	Notes	Date
A	Initial release	02/09
B	Introduced Max current limit when V DRAIN is below 400 V	07/09
C	Added Clampless® design note on page 3	09/09

For the latest updates, visit our website: www.powerint.com

Power Integrations reserves the right to make changes to its products at any time to improve reliability or manufacturability. Power Integrations does not assume any liability arising from the use of any device or circuit described herein. POWER INTEGRATIONS MAKES NO WARRANTY HEREIN AND SPECIFICALLY DISCLAIMS ALL WARRANTIES INCLUDING, WITHOUT LIMITATION, THE IMPLIED WARRANTIES OF MERCHANTABILITY, FITNESS FOR A PARTICULAR PURPOSE, AND NON-INFRINGEMENT OF THIRD PARTY RIGHTS.

Patent Information

The products and applications illustrated herein (including transformer construction and circuits external to the products) may be covered by one or more U.S. and foreign patents, or potentially by pending U.S. and foreign patent applications assigned to Power Integrations. A complete list of Power Integrations patents may be found at www.powerint.com. Power Integrations grants its customers a license under certain patent rights as set forth at <http://www.powerint.com/ip.htm>.

Life Support Policy

POWER INTEGRATIONS PRODUCTS ARE NOT AUTHORIZED FOR USE AS CRITICAL COMPONENTS IN LIFE SUPPORT DEVICES OR SYSTEMS WITHOUT THE EXPRESS WRITTEN APPROVAL OF THE PRESIDENT OF POWER INTEGRATIONS. As used herein:

1. A Life support device or system is one which, (i) is intended for surgical implant into the body, or (ii) supports or sustains life, and (iii) whose failure to perform, when properly used in accordance with instructions for use, can be reasonably expected to result in significant injury or death to the user.
2. A critical component is any component of a life support device or system whose failure to perform can be reasonably expected to cause the failure of the life support device or system, or to affect its safety or effectiveness.

The PI logo, TOPSwitch, TinySwitch, LinkSwitch, DPA-Switch, PeakSwitch, EcoSmart, Clampless, E-Shield, Filterfuse, StakFET, PI Expert and PI FACTS are trademarks of Power Integrations, Inc. Other trademarks are property of their respective companies.

©2009, Power Integrations, Inc.

Power Integrations Worldwide Sales Support Locations

World Headquarters

5245 Hellyer Avenue
San Jose, CA 95138, USA.
Main: +1-408-414-9200
Customer Service:
Phone: +1-408-414-9665
Fax: +1-408-414-9765
e-mail: usasales@powerint.com

China (Shanghai)

Room 1601/1610, Tower 1
Kerry Everbright City
No. 218 Tianmu Road West
Shanghai, P.R.C. 200070
Phone: +86-21-6354-6323
Fax: +86-21-6354-6325
e-mail: chinasales@powerint.com

China (Shenzhen)

Rm A, B & C 4th Floor, Block C,
Electronics Science and
Technology Bldg., 2070
Shennan Zhong Rd,
Shenzhen, Guangdong,
China, 518031
Phone: +86-755-8379-3243
Fax: +86-755-8379-5828
e-mail: chinasales@powerint.com

Germany

Rueckertstrasse 3
D-80336, Munich
Germany
Phone: +49-89-5527-3910
Fax: +49-89-5527-3920
e-mail: eurosales@powerint.com

India

#1, 14th Main Road
Vasanthanagar
Bangalore-560052 India
Phone: +91-80-4113-8020
Fax: +91-80-4113-8023
e-mail: indiasales@powerint.com

Italy

Via De Amicis 2
20091 Bresso MI
Italy
Phone: +39-028-928-6000
Fax: +39-028-928-6009
e-mail: eurosales@powerint.com

Japan

Kosei Dai-3 Bldg.
2-12-11, Shin-Yokohama,
Kohoku-ku
Yokohama-shi Kanagwan
222-0033 Japan
Phone: +81-45-471-1021
Fax: +81-45-471-3717
e-mail: japansales@powerint.com

Korea

RM 602, 6FL
Korea City Air Terminal B/D, 159-6
Samsung-Dong, Kangnam-Gu,
Seoul, 135-728, Korea
Phone: +82-2-2016-6610
Fax: +82-2-2016-6630
e-mail: koreasales@powerint.com

Singapore

51 Newton Road
#15-08/10 Goldhill Plaza
Singapore, 308900
Phone: +65-6358-2160
Fax: +65-6358-2015
e-mail: singaporesales@powerint.com

Taiwan

5F, No. 318, Nei Hu Rd., Sec. 1
Nei Hu Dist.
Taipei, Taiwan 114, R.O.C.
Phone: +886-2-2659-4570
Fax: +886-2-2659-4550
e-mail: taiwansales@powerint.com

Europe HQ

1st Floor, St. James's House
East Street, Farnham
Surrey GU9 7TJ
United Kingdom
Phone: +44 (0) 1252-730-141
Fax: +44 (0) 1252-727-689
e-mail: eurosales@powerint.com

Applications Hotline

World Wide +1-408-414-9660

Applications Fax

World Wide +1-408-414-9760
